

FMM, FZM, and FDM Series Monitor Modules with FlashScan®

Section: Intelligent/Addressable Devices

GENERAL

Four different monitor modules are available for NOTIFIER intelligent controls to suit a variety of applications. Monitor modules are used to supervise a circuit of dry-contact input devices, such as conventional heat detectors and pull stations, or monitor and power a circuit of two-wire smoke detectors (FZM-1).

FMM-1 — is a standard-sized module (typically mounts to a 4" [101.6 mm] square box) that supervises either a Class A (Style D) or Class B (Style B) circuit of dry-contact input devices.

FMM-101 — is a miniature monitor module (a mere 1.3" (33.02 mm) H x 2.75" (69.85 mm) W x 0.5" (12.70 mm) D) used to supervise a Class B (Style B) circuit. Its compact design allows the FMM-101 to often be mounted in a single-gang box behind the device it's monitoring.

FZM-1 — is a standard-sized module used to monitor and supervise compatible two-wire, 24 volt, smoke detectors on a Class A (Style D) or Class B (Style B) circuit.

FDM-1 — is a standard-sized dual monitor module used to monitor and supervise two independent two-wire initiating device circuits (IDCs) at two separate, consecutive addresses in intelligent, two-wire systems.

FlashScan® (U.S. Patent 5,539,389) is a new communication protocol developed by NOTIFIER Engineering that greatly enhances the speed of communication between analog intelligent devices. Intelligent devices communicate in a grouped fashion. If one of the devices within the group has new information, the panel CPU stops the group poll and concentrates on single points. The net effect is response speed **greater than five times** that of other designs.

FlashScan® is a registered trademark of NOTIFIER.

FMM-1 MONITOR MODULE

- Built-in type identification automatically identifies this device as a monitor module to the control panel.
- Powered directly by two-wire SLC loop. No additional power required.
- High noise (EMF/RFI) immunity.
- SEMS screws with clamping plates for ease of wiring.
- Direct-dial entry of address 01 – 159 (01 – 99 on traditional systems).
- LED flashes green during normal operation (this is a programmable option) and latches on steady red to indicate alarm.

The **FMM-1 Monitor Module** is intended for use in intelligent, two-wire systems, where the individual address of each module is selected using the built-in rotary switches. It provides either a two-wire or four-wire fault-tolerant Initiating Device Circuit (IDC) for normally-open-contact fire alarm and supervisory devices. The module has a panel-controlled LED indicator. The FMM-1 can be used to replace MMX-1 modules in existing systems.



California
State Fire
Marshal
7300-0028:202



MARYLAND
State Fire Marshal

Permit # 2020
(except FDM-1)

MEA

143-01-E (FDM-1)
457-99-E (FMM-1,
FMM-101, FZM-1)

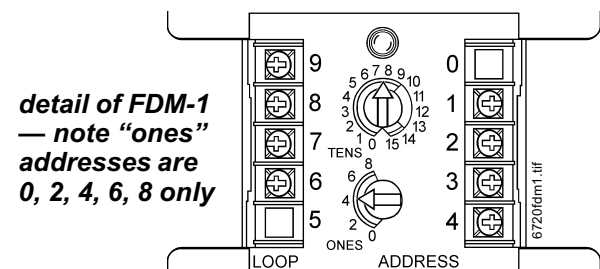
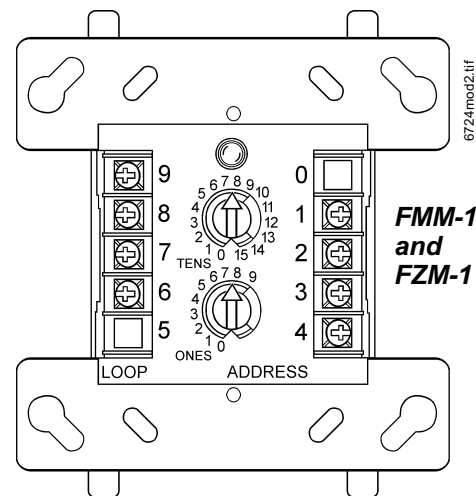

detail of FDM-1
— note "ones"
addresses are
0, 2, 4, 6, 8 only

FMM-1 Applications — Use to monitor a zone of four-wire smoke detectors, manual fire alarm pull stations, waterflow devices, or other normally-open dry-contact alarm activation devices. May also be used to monitor normally-open supervisory devices with **special supervisory indication** at the control panel. Monitored circuit may be wired as an NFPA Style B (Class B) or Style D (Class A) Initiating Device Circuit. A 47K ohm End-of-Line Resistor (provided) terminates the Style B circuit. No resistor is required for supervision of the Style D circuit. Maximum IDC loop length is 2,500 ft./762 m (20 ohms maximum).

This document is not intended to be used for installation purposes. We try to keep our product information up-to-date and accurate. We cannot cover all specific applications or anticipate all requirements. All specifications are subject to change without notice. For more information, contact NOTIFIER. Phone: (203) 484-7161 FAX: (203) 484-7118



NOTIFIER®

12 Clintonville Road, Northford, Connecticut 06472

ISO 9001
CERTIFIED
ENGINEERING & MANUFACTURING

FMM-1 Operation — Each FMM-1 uses one of 159 available module addresses on an SLC loop. It responds to regular polls from the control panel and reports its type and the status (open/normal/short) of its Initiating Device Circuit (IDC). A **flashing LED** indicates that the module is in communication with the control panel. The LED latches steady on alarm (subject to **current limitations** on the loop).

FMM-1 Specifications

- Nominal operating voltage:** 15 to 32 VDC.
- Maximum current draw:** 5.1 mA (LED on).
- Maximum operating current:** 375 µA (LED flashing).
- EOL resistance:** 47K ohms.
- Temperature range:** 32°F to 120°F (0°C to 49°C).
- Humidity range:** 10% to 93% noncondensing.
- Dimensions:** 4.5" (114.3 mm) high x 4" (101.6 mm) wide x 1.25" (31.75 mm) deep. Mounts to a 4" (101.6 mm) square x 2.125" (53.975 mm) deep box.

FMM-101 MINI MONITOR MODULE

- Built-in type identification automatically identifies this device as a monitor module to the AFC-600.
- Powered directly by two-wire FACP. No additional power required.
- High noise (EMF/RFI) immunity.
- Tinned, stripped leads for ease of wiring.
- Direct-dial entry of address (01-159).

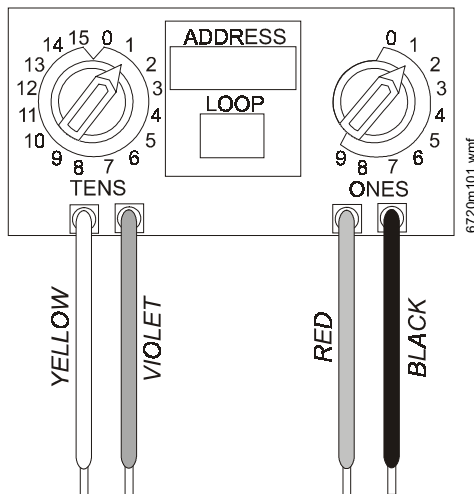

The **FMM-101 Mini Monitor Module** can be installed in a single-gang junction directly behind the monitored unit. Its small size and light weight allow it to be installed without rigid mounting. The FMM-101 is intended for use in intelligent, two-wire systems where the individual address of each module is selected using rotary switches. It provides a two-wire initiating device circuit for normally-open-contact fire alarm and security devices. The FMM-101 can be used to replace MMX-101 module in existing systems.

FMM-101 Applications — Use to monitor a single device or a zone of four-wire smoke detectors, manual fire alarm pull stations, waterflow devices, or other normally-open dry-contact devices. May also be used to monitor normally-open supervisory devices with special supervisory indication at the control panel. Monitored circuit/device is wired as an NFPA Style B (Class B) Initiating Device Circuit. A 47K ohm End-of-Line Resistor (provided) terminates the circuit.

FMM-101 Operation — Each FMM-101 uses one of 159 available module addresses on an SLC loop. It responds to regular polls from the control panel and reports its type

and the status (open/normal/short) of its Initiating Device Circuit (IDC).

FMM-101 Specifications

- Nominal operating voltage:** 15 to 32 VDC.
- Maximum operating current:** 375 µA.
- EOL resistance:** 47K ohms.
- Temperature range:** 32°F to 120°F (0°C to 49°C).
- Humidity range:** 10% to 93% noncondensing.
- Dimensions:** 1.3" (33.02 mm) high x 2.75" (69.85 mm) wide x 0.5" (12.70 mm) deep.
- Wire length:** 6" (152.4 mm) minimum.

FZM-1 INTERFACE MODULE

- Supports compatible two-wire smoke detectors.
- Supervises IDC wiring and connection of external power source.
- High noise (EMF/RFI) immunity.
- SEMS screws with clamping plates for ease of wiring.
- Direct-dial entry of address (01-159).
- LED flashes during normal operation (this is a programmable option).
- LED latches steady to indicate alarm on command from control panel.

The **FZM-1 Interface Module** is intended for use in intelligent, addressable systems, where the individual address of each module is selected using built-in rotary switches. This module allows intelligent panels to interface and monitor two-wire conventional smoke detectors. It transmits the status (normal, open, or alarm) of one full zone of conventional detectors back to the control panel. All two-wire detectors being monitored must be UL compatible with the module. The FZM-1 has a panel-controlled LED indicator and can be used to replace MMX-2 modules in existing systems.

FZM-1 Applications — Use the FZM-1 to monitor a zone of two-wire smoke detectors. The monitored circuit may be wired as an NFPA Style B (Class B) or Style D (Class A) Initiating Device Circuit. A 3.9 K ohm End-of-Line Resistor (provided) terminates the end of the Style B or D (class B or A) circuit (maximum IDC loop resistance is 25 ohms). Install ELR across terminals 8 and 9 for Style D application.

FZM-1 Operation — Each FZM-1 uses one of 159 available module addresses on an SLC loop. It responds to regular polls from the control panel and reports its type and the status (open/normal/short) of its Initiating Device Circuit (IDC). A flashing LED indicates that the module is in communication with the control panel. The LED latches steady on alarm (subject to current limitations on the loop).

FZM-1 Specifications

- Nominal operating voltage:** 15 to 32 VDC.
- Maximum current draw:** 5.1 mA (LED on).
- Maximum operating current:** 255 µA (LED flashing).
- EOL resistance:** 3.9K ohms.
- External supply voltage (between Terminals T3 and T4):** **DC voltage:** 18 to 28 volts power limited. **Ripple voltage:** 0.1 V_{RMS} maximum. **Current:** 90 mA per module maximum.
- Temperature range:** 32°F to 120°F (0°C to 49°C).
- Humidity range:** 10% to 93% noncondensing.
- Dimensions:** 4.5" (114.3 mm) high x 4" (101.6 mm) wide x 1.25" (31.75 mm) deep. Mounts to a 4" (101.6 mm) square x 2.125" (53.975 mm) deep box.

FDM-1 DUAL MONITOR MODULE

The FDM-1 Dual Monitor Module is intended for use in intelligent, two-wire systems. It provides two independent two-wire initiating device circuits (IDCs) at two separate, consecutive addresses. It is capable of monitoring normally open contact fire alarm and supervisory devices; or either normally open or normally closed security devices. The module has a single panel-controlled LED. **NOTE:** The FDM-1 provides two Class B (Style Y) IDC circuits **ONLY**. Class A (Style Z) IDC circuits are **NOT** supported in any application.

FDM-1 Specifications

Normal operating voltage range: 15 to 32 VDC.

Maximum current draw: 5.7 mA (LED on).

Maximum operating current: 750 μ A (LED flashing).

EOL resistance: 47K ohms.

Maximum IDC wiring resistance: 1,500 ohms.

Temperature range: 32° to 120°F (0° to 49°C).

Humidity range: 10% to 93% (non-condensing).

Dimensions: 4.5" (114.3 mm) high x 4" (101.6 mm) wide x 2.125" (53.975 mm) deep.

FDM-1 Automatic Addressing — The FDM-1 automatically assigns itself to two addressable points, starting with the original address. For example, if the FDM-1 is set to address "56", then it will automatically assign itself to addresses "56" and "57". **NOTE:** "ones" addresses on the FDM-1 are 0, 2, 4, 6, or 8 **only**. Terminals 6 and 7 use the first address, and terminals 8 and 9 use the second address.

CAUTION!

Avoid duplicating addresses on the system.

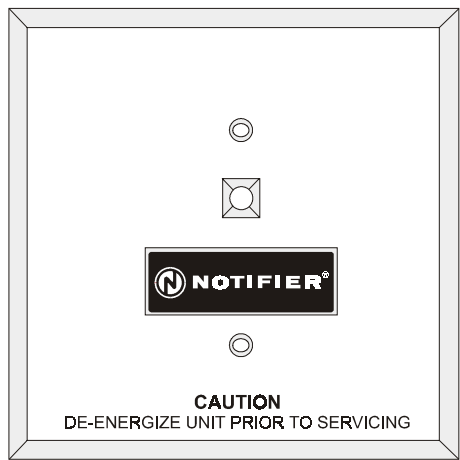

Face Plate for FMM-1, FZM-1, and FDM-1

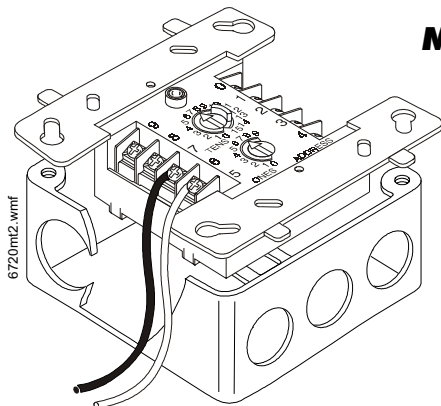

MOUNTING DIAGRAMS for standard-sized modules

INSTALLATION

FMM-1, FDM-1, and FZM-1 modules mount directly to a standard 4" (101.6 mm) square, 2.125" (53.975 mm) deep, electrical box. They may also be mounted to the SMB500 surface-mount box. Mounting hardware and installation instructions are provided with each module. All wiring must conform to applicable local codes, ordinances, and regulations. These modules are intended for power-limited wiring only.

The FMM-101 module is intended to be wired and mounted without rigid connections inside a standard electrical box. All wiring must conform to applicable local codes, ordinances, and regulations.

PRODUCT LINE INFORMATION

Model	Description
FMM-1	Monitor module.
FMM-101	Monitor module, miniature.
FZM-1	Monitor module, two-wire detectors
FDM-1	Monitor module, dual, two independent Class B circuits.
SMB500	Optional surface-mount backbox.

ARCHITECTS'/ENGINEERS' SPECIFICATIONS

Specifications of these and all NOTIFIER products are available from NOTIFIER.

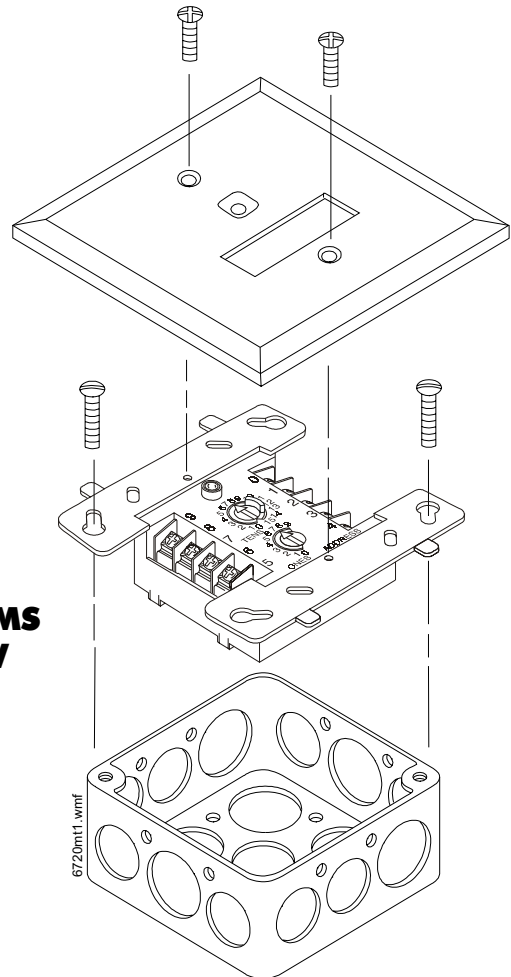

WIRING DIAGRAMS

The following wiring diagrams are included:

- 1) FDM-1, typical dual two-wire Style B initiating device circuit configuration.
- 2) FMM-101, typical two-wire Style B initiating device circuit configuration.
- 3) FMM-1, typical two-wire initiating circuit configuration, NFPA Style B.
- 4) FMM-1, typical four-wire fault-tolerant initiating circuit configuration, NFPA Style D.
- 5) FMM-1, typical two-wire initiating circuit configuration for security systems (with alarm versus short capability).
- 6) FZM-1, interface two-wire conventional detectors, NFPA Style B.
- 7) FZM-1, interface two-wire conventional detectors, NFPA Style D.
- 8) FRM-1, relay control module used to disconnect a power supply.

WIRING DIAGRAM: FDM-1

Fig. 1 FDM-1: Typical dual two-wire Style B initiating device circuit configuration.

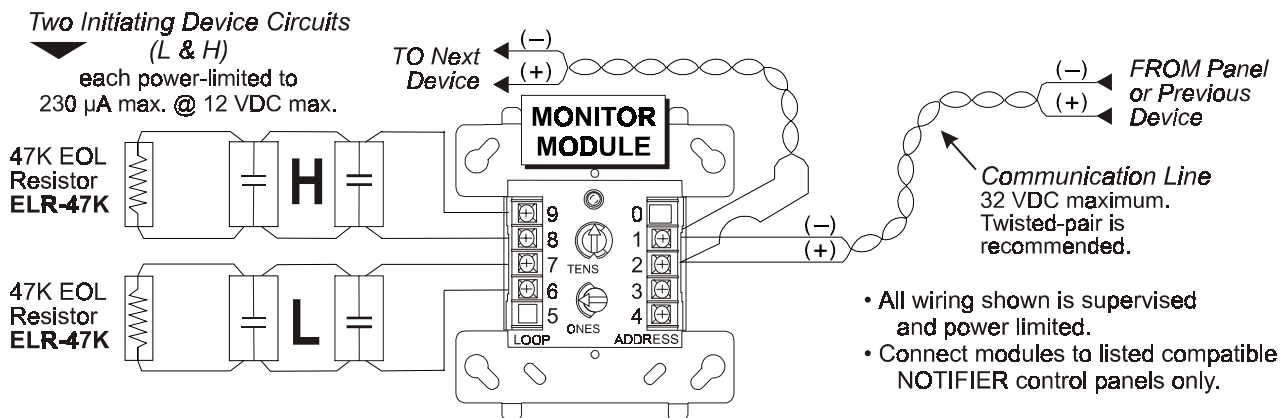

- ANY NUMBER of UL Listed contact closure devices may be used.
- DO NOT MIX fire alarm initiating, supervisory, or security devices on the same circuit.
- Install contact closure devices per manufacturer's installation instructions.

6822wir1.wmf

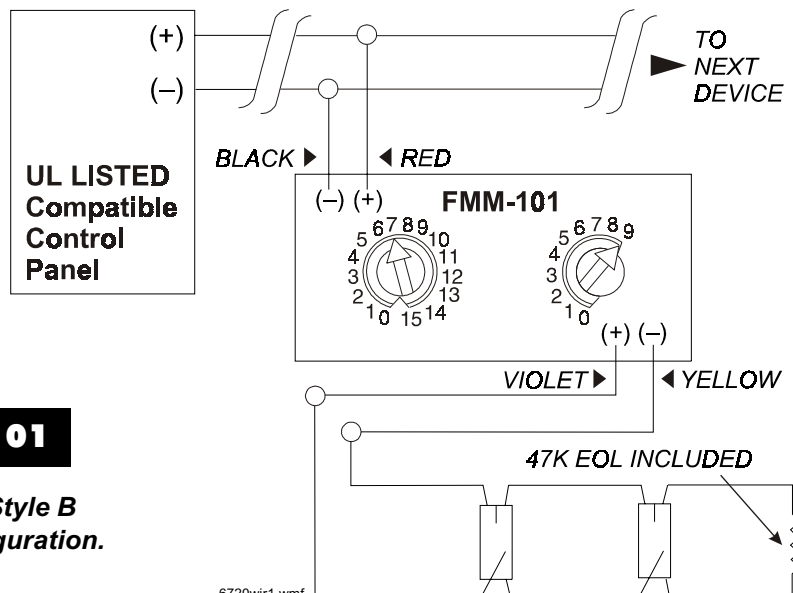

WIRING DIAGRAM: FMM-101

Fig. 2 FMM-101: Typical two-wire Style B initiating device circuit configuration.

6720wir1.wmf

WIRING DIAGRAMS THIS PAGE: FMM-1

- Connect modules to listed compatible NOTIFIER control panels only.
- All wiring shown is supervised and power limited.
- Install contact closure devices per manufacturers' installation instructions.
- Any number of UL-listed contact closure devices may be used.
- **DO NOT MIX** fire alarm initiating, supervisory, or security devices on the same circuit.

▼ **Fig. 3 FMM-1: Typical two-wire initiating device circuit configuration, NFPA Style B.**

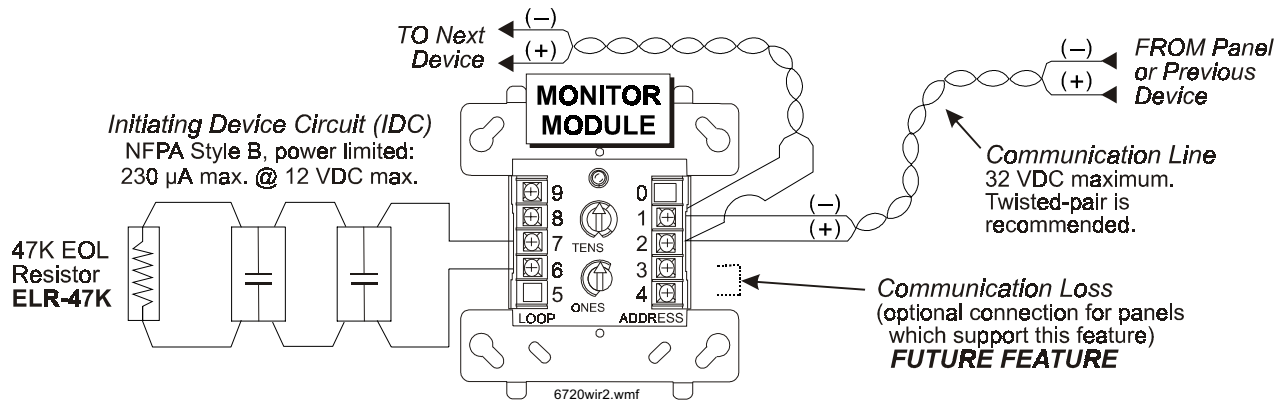

▼ **Fig. 4 FMM-1: Typical four-wire fault-tolerant initiating circuit configuration, NFPA Style D.**

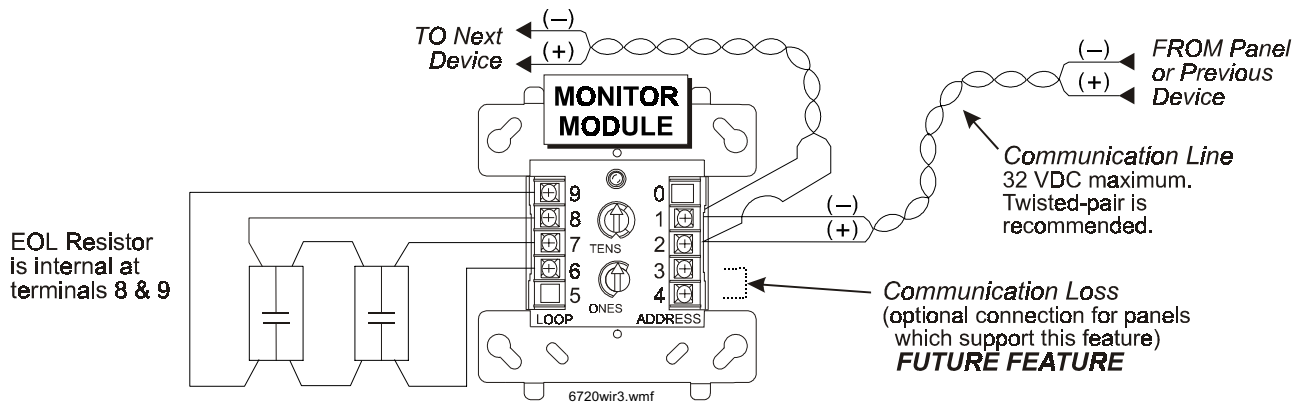

▼ **Fig. 5 FMM-1: Typical two-wire initiating circuit configuration for security systems (with alarm versus short capability).**

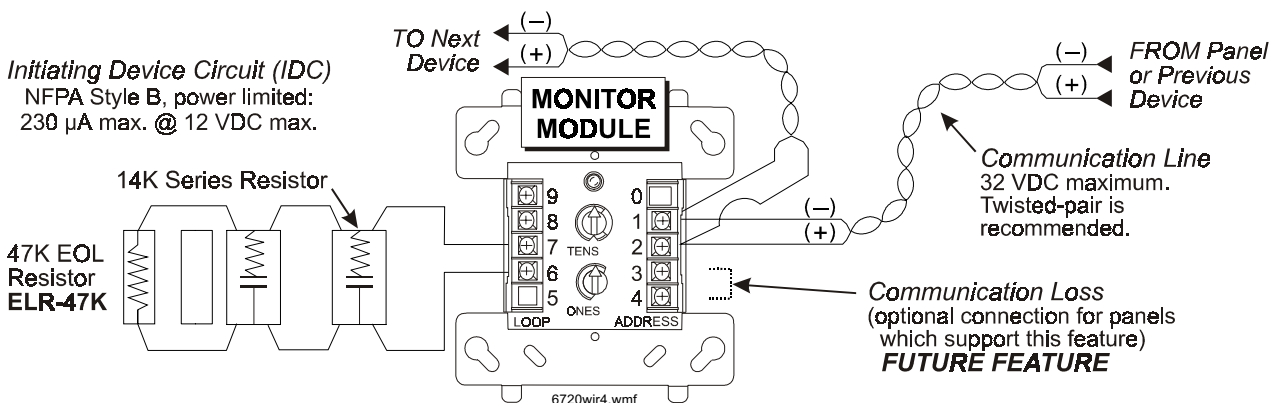

- Connect modules to listed compatible control panels only.
- Terminal wiring must be power limited.
- **DO NOT MIX** fire alarm initiating, supervisory, or security devices on the same circuit.
- **DO NOT LOOP** wire under terminals. Break wire run to provide supervision of connections.
- Detectors must be UL listed compatible with module.
- Install detectors per manufacturers' installation instructions.
- Power to the interface module must be externally switched to reset the detectors. An **FRM-1** relay control module can be used to switch power from a standard power supply; *see Fig. 7 below.*

**WIRING
DIAGRAMS
THIS PAGE:
FZM-1, FRM-1**

▼ **Fig. 6 FZM-1: Interface two-wire conventional detectors, NFPA Style B.**

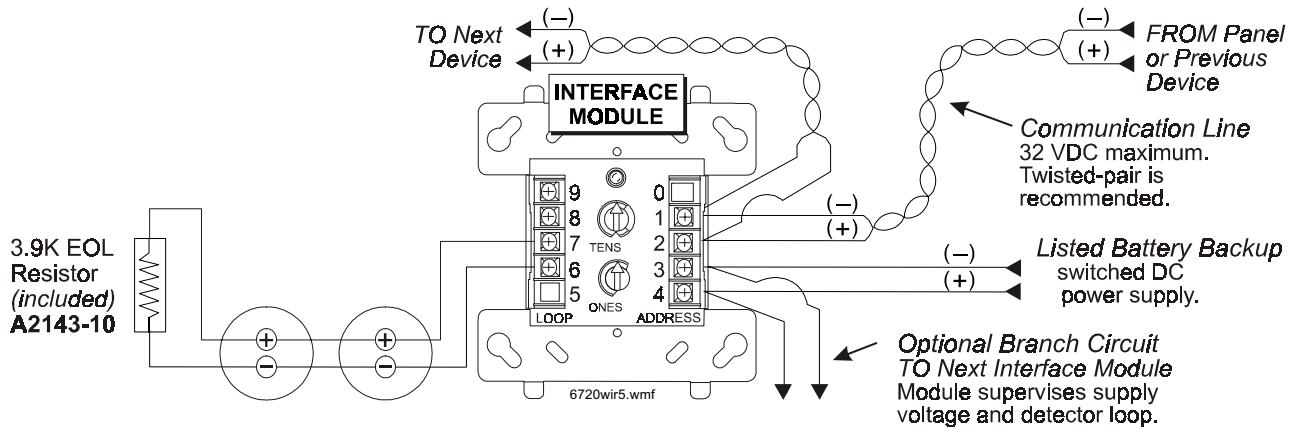

▼ **Fig. 7 FZM-1: Interface two-wire conventional detectors, NFPA Style D.**

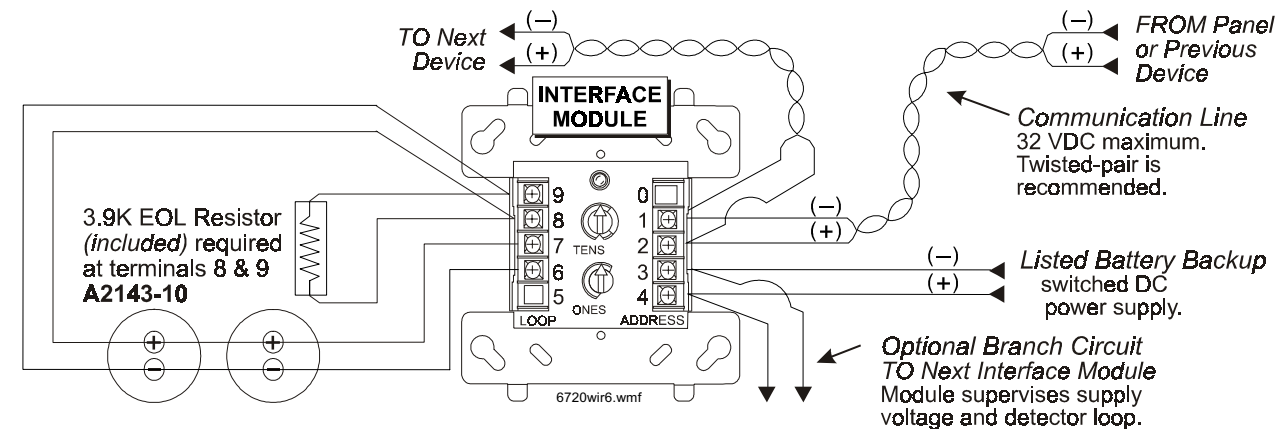

▼ **Fig. 8 FRM-1: Relay control module used to disconnect a power supply.**

